

NON-CONTROLLED COPY
 INFORMATION SUBJECT TO CHANGE WITHOUT NOTICE
 VERIFY REV LEVEL OF PAPER COPY WITH REV LEVEL ON PPC WEB SITE

NOZZLE SCHEDULE & ACCESSORIES					
SERVICE	MK	STOCK NO.	SIZE	FITTING	DEG ELEV

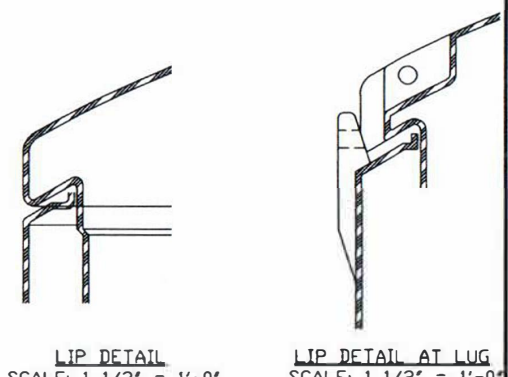
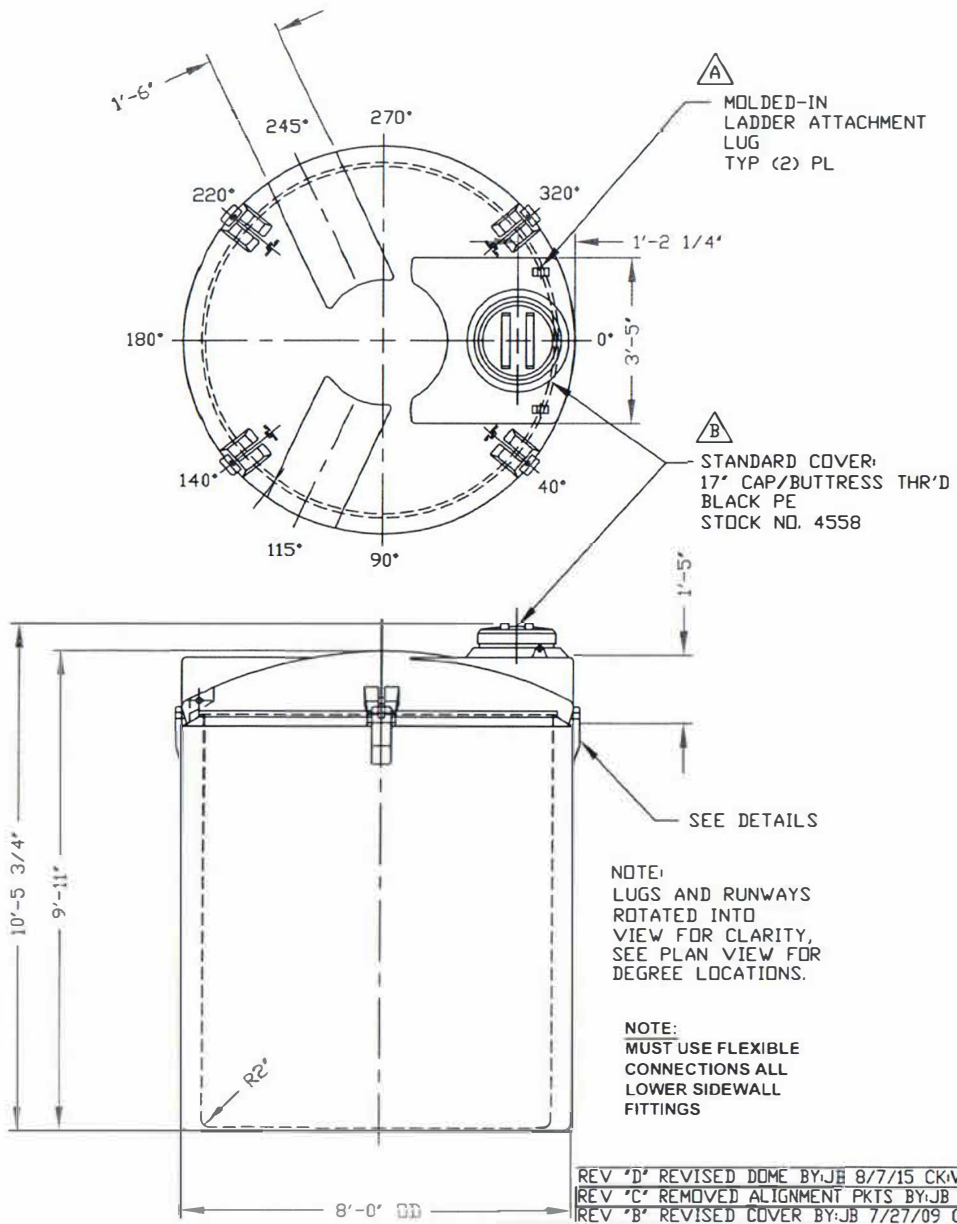

- NOTES:**
- THIS IS A COMPUTER GENERATED DWG. DO NOT REVISE BY HAND.
 - DIMENSIONS WILL VARY ±3% DUE TO VARIATIONS IN MULTIPLE MOLDS & CONDITIONS PREVALENT DURING MANUFACTURE & USAGE.
 - FOR INNER TANK DTLS SEE COMPUTER FILE NO. 12002500 TITLE '2500 GALLON INNER SAFE-TANK.' FOR OUTER TANK DTLS SEE COMPUTER FILE NO. 12103100, TITLE '2500 GALLON OUTER SAFE-TANK/2500 OPEN TOP TANK'.

CALCULATED CAPACITIES/ VOLUME IN U.S. GALLONS			
TANK	DESIGN CAP	DOME VOL	TOTAL VOL
INNER	2517	246	2763
OUTER	3125	N/A	3125